

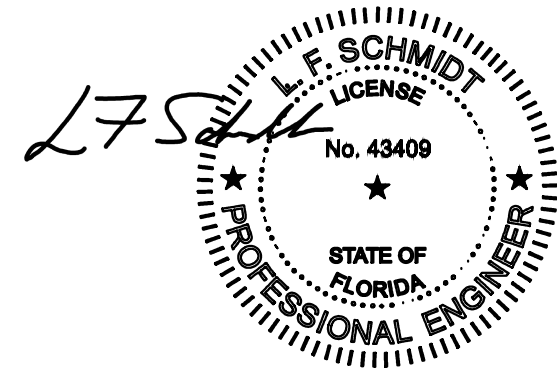

# "VERIS V3" GLAZED ALUMINUM DOOR DOUBLE w/ or w/out SIDELITES OUTSWING "IMPACT"



This item has been digitally signed and sealed by L. F. Schmidt, P.E. on the date adjacent to the seal. Printed copies of this document are not considered signed and sealed and the signature must be verified on any electronic copies.

THIS PRODUCT APPROVAL IS VALID ONLY FOR THE STATE OF FLORIDA

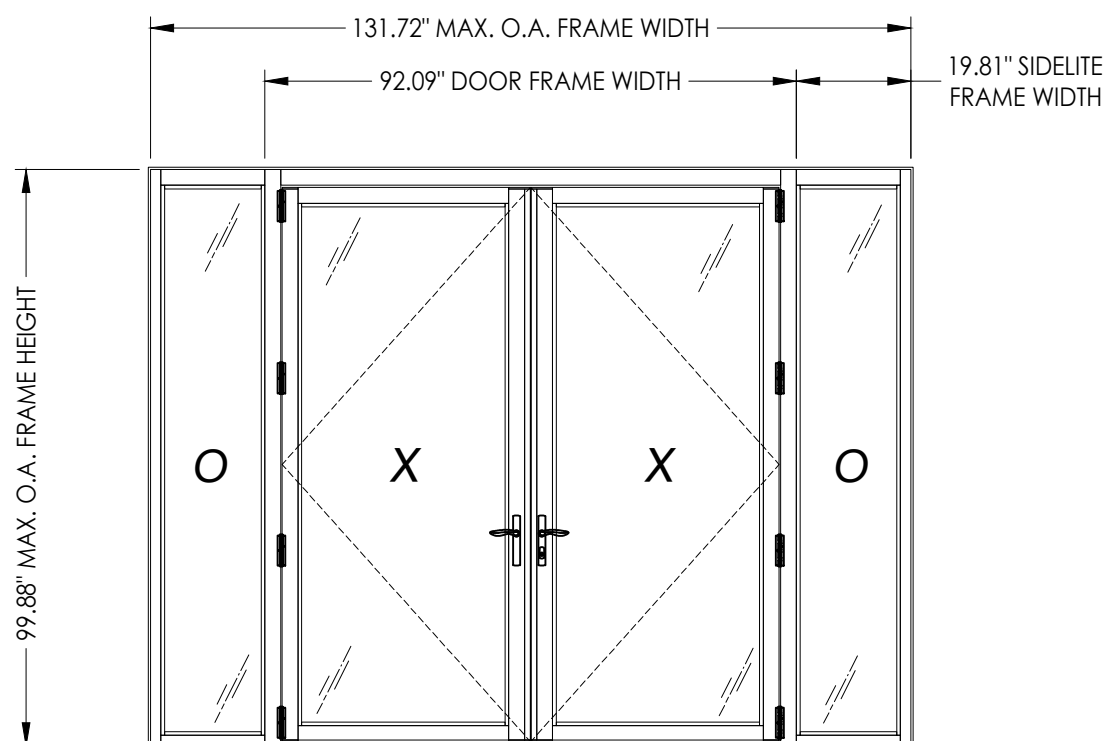
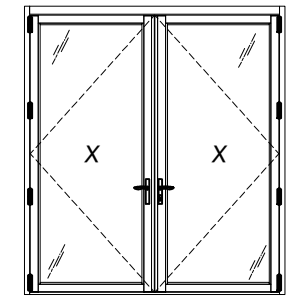

### GENERAL NOTES

1. This product has been evaluated and is in compliance with the 8th Edition (2023) Florida Building Code (FBC) structural requirements excluding the "High Velocity Hurricane Zone" (HVHZ).
2. Product anchors shall be as listed and spaced as shown on details. Anchor embedment to base material shall be beyond wall dressing or stucco.
3. When used in areas requiring wind borne debris protection this product complies with FBC Sections 1609.1.2 & R301.2.1.2 and does not require an impact resistant covering. This product meets missile level "D" and includes Wind Zone 4 as defined in ASTM E1996 and FBC Sections 1609.1.2.2 & R301.2.1.2.1.
4. For 2x stud framing construction, anchoring of these units shall be the same as that shown for 2x buck masonry construction.
5. Site conditions that deviate from the details of this drawing require further engineering analysis by a licensed engineer or registered architect.

### TABLE OF CONTENTS

SHEET #	DESCRIPTION
1	Typical Elevations, Design Pressures & General Notes
2	Door & Sidelite Panels & Glazing Details
3	Elevations
4	Horizontal & Vertical Cross Sections (2X Buck)
5	Horizontal & Vertical Cross Sections (1X Buck)
6	Horizontal & Vertical Cross Sections (Direct to Masonry)
7	Horizontal Cross Sections
8	Vertical Cross Sections
9	Buck Anchoring
10	Frame Anchoring
11	Bill of Materials & Components

CONFIGURATION	MAX. FRAME DIMENSION	DOOR MAX. D.L.O.	SIDELITE MAX. D.L.O.	DESIGN PRESSURE (PSF)	
				POSITIVE	NEGATIVE
OXXO	131.72" x 99.88"	35.25" X 89.25"	16.75" X 94.06"	+50.0	-50.0
XX	90.22" x 99.88"	35.25" X 89.25"	N/A	+50.0	-50.0

Documents Prepared By:  
Lyndon F. Schmidt  
P.E. No. 43409

*RW*  
BUILDING CONSULTANTS, INC.  
P.O. Box 230, Valrico, FL 33595  
Phone No.: 813.659.9197  
FBPE Registry No. 9813

PRODUCT: THERMA TRU  
PART OR ASSEMBLY: TYPICAL ELEVATION, DESIGN PRESSURES & GENERAL NOTES

NO.	DATE	BY	REVISIONS

DATE: 2/07/24  
SCALE: N.T.S.  
DWG. BY: LFS  
CHK. BY: RW  
DRAWING NO.: FL-46172.6  
SHEET 1 OF 11

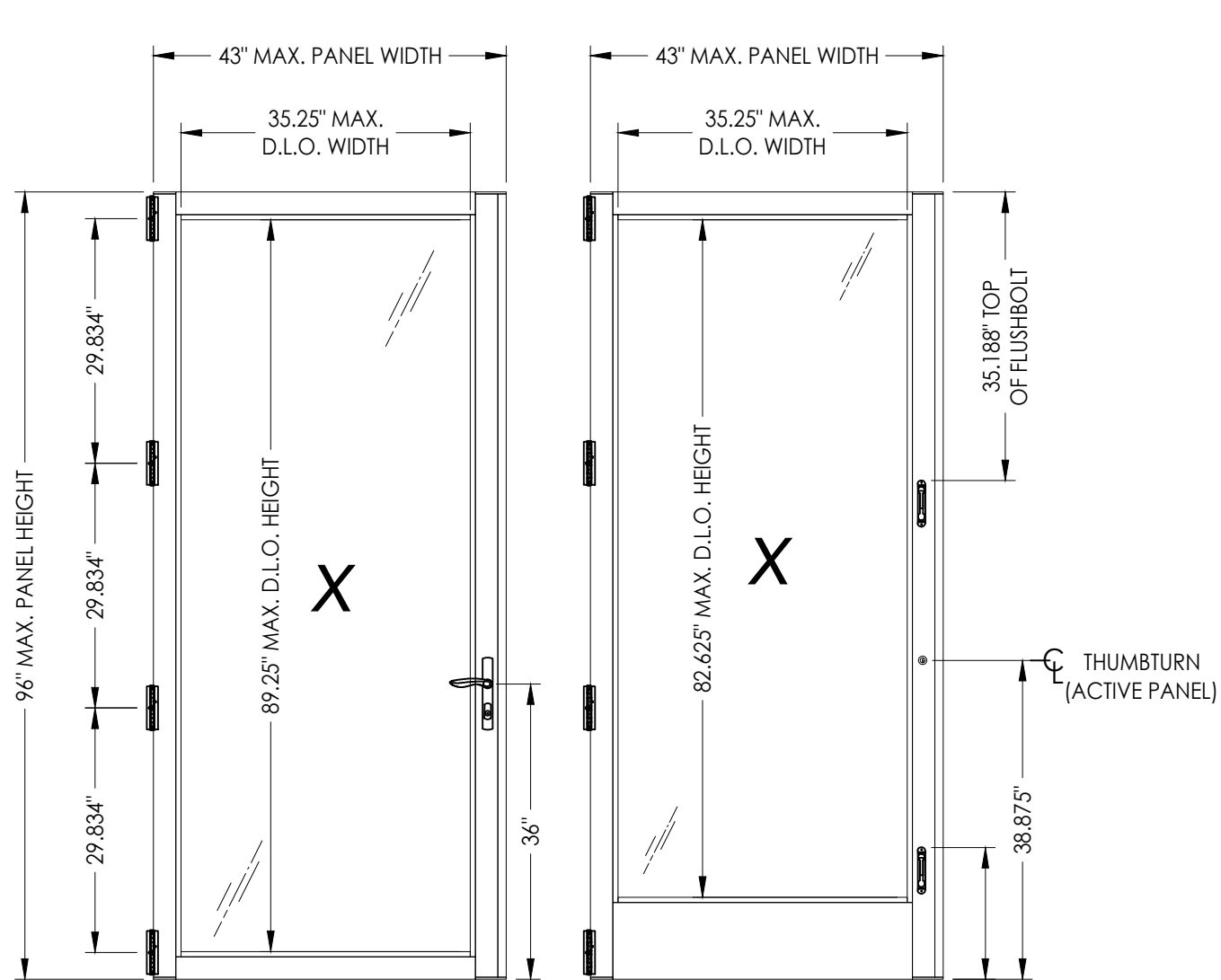

DOOR PANEL

DOOR PANEL

SIDELITE PANEL

HARDWARE TABLE	
MANUFACTURER	MODEL
HOPPE	<b>HOPPE HLS9000</b>
	ACTIVE: LEVER w/ 3 pt. LOCK INACTIVE: LEVER w/ 2 pt. LOCK
ADAMS RITE	ACTIVE: THUMBTURN & KEYED CYLINDER MS+ 1890 SERIES DEADBOLT
TERRY HINGE & HARDWARE	ACTIVE & INACTIVE: FLUSHBOLTS

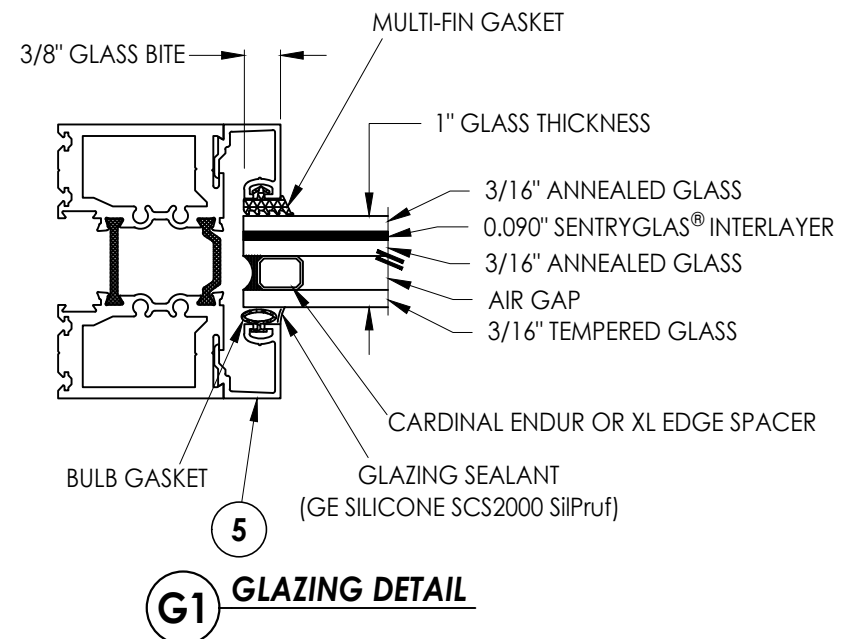

G1 GLAZING DETAIL

Documents Prepared By:  
Lyndon F. Schmidt  
P.E. No. 43409

*RW* BUILDING CONSULTANTS, INC.  
P.O. Box 230, Valrico, FL 33595  
Phone No.: 813.659.9197  
FBPE Registry No. 9813

PRODUCT: THERMA-TRU

PART OR ASSEMBLY:  
DOOR & SIDELITE PANELS &  
GLAZING DETAILS

NO. DATE BY

REVISIONS

DATE: 2/07/24

SCALE: N.T.S.

DWG. BY: LFS

CHK. BY: RW

DRAWING NO.:  
FL-46172.6

SHEET 2 of 11

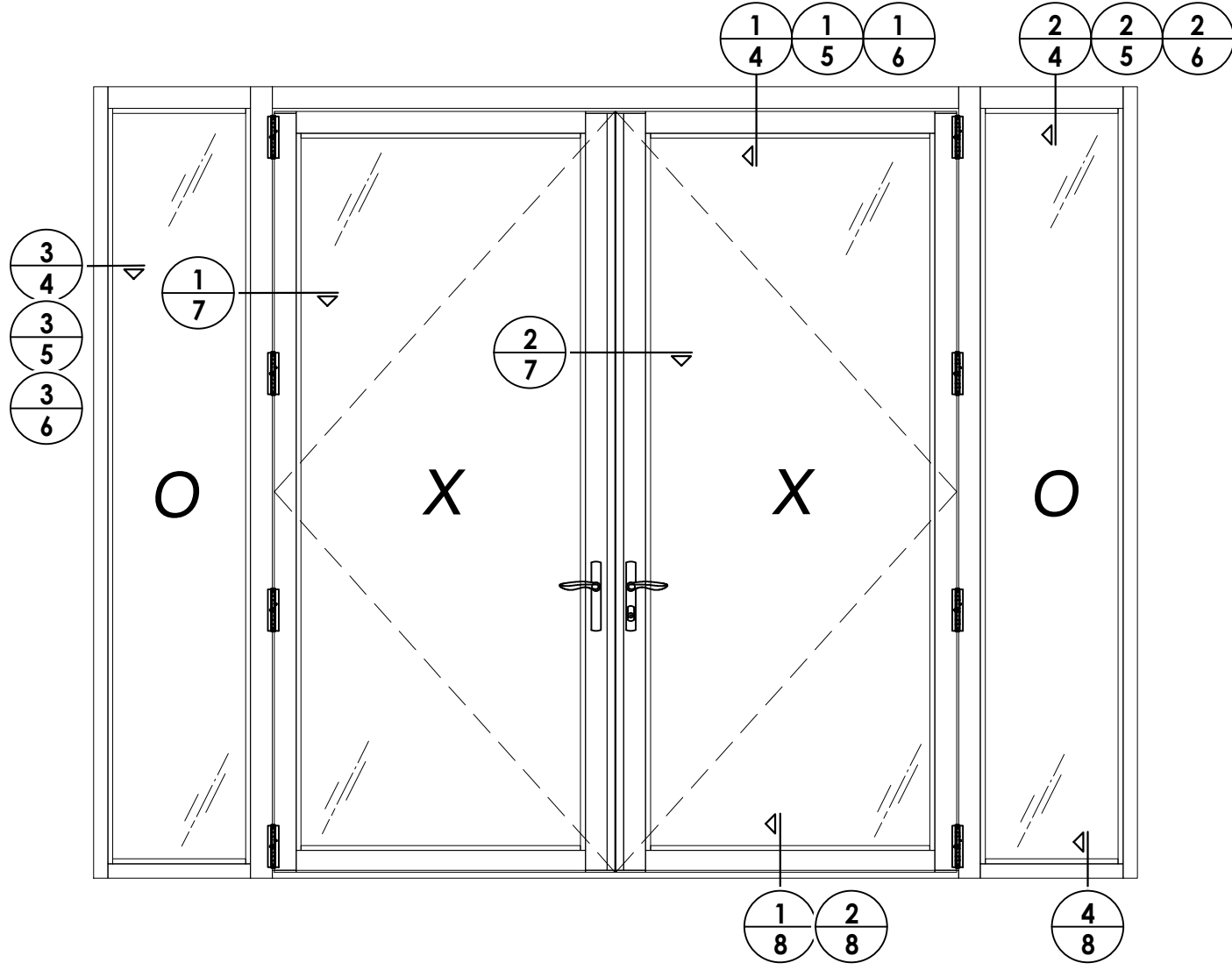
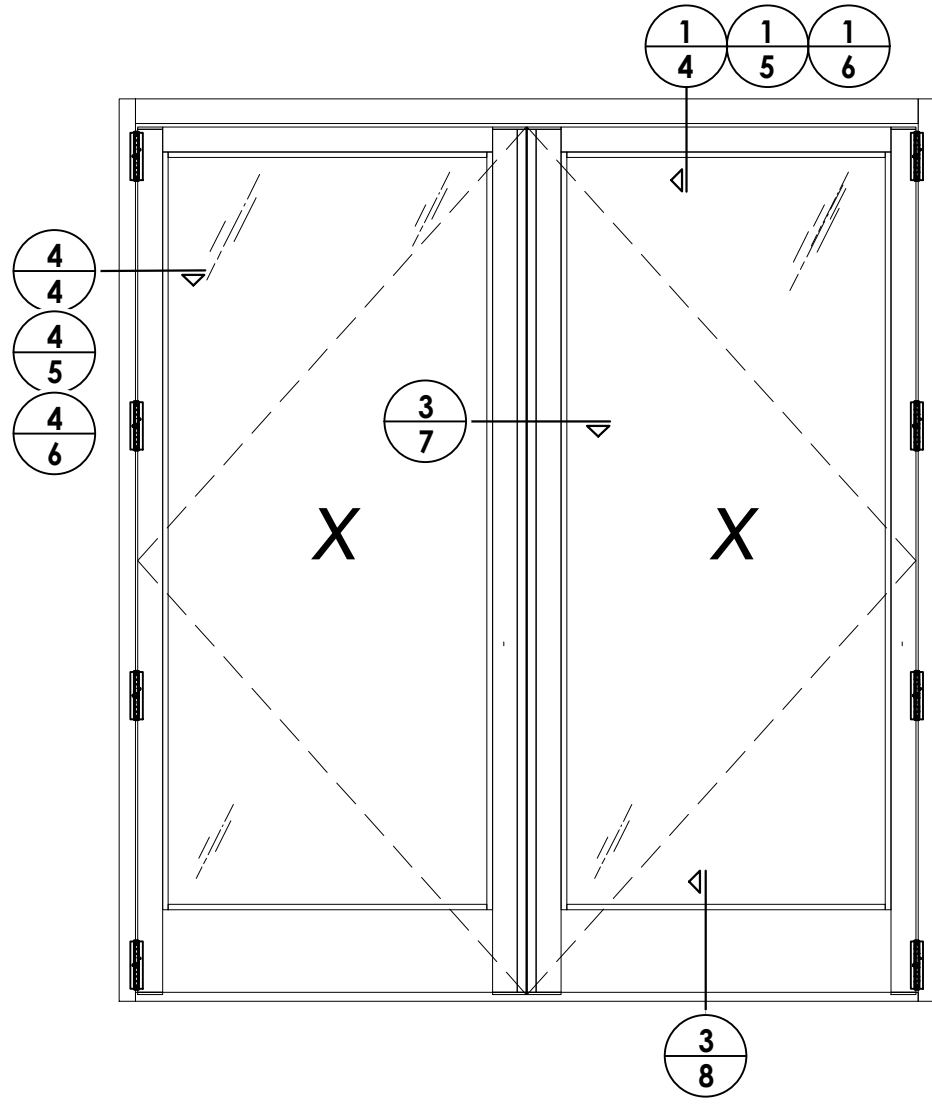

DATE: 2/07/24  
 SCALE: N.T.S.  
 DWG. BY: LFS  
 CHK. BY: RW  
 DRAWING NO.: FL-46172.6  
 SHEET 3 OF 11

NO.	DATE	BY	REVISIONS

PRODUCT: THERMA-TRU  
 PART OR ASSEMBLY: ELEVATIONS

Documents Prepared By:  
 Lyndon F. Schmidt  
 P.E. No. 43409  
**RW** BUILDING CONSULTANTS, INC.  
 P.O. Box 230, Vairico, FL 33595  
 Phone No.: 813.659.9197  
 FBPE Registry No. 9813

Z:\2023 FBC Drawings\Therma-Tru\FL-46172\FL 46172.6.dwg

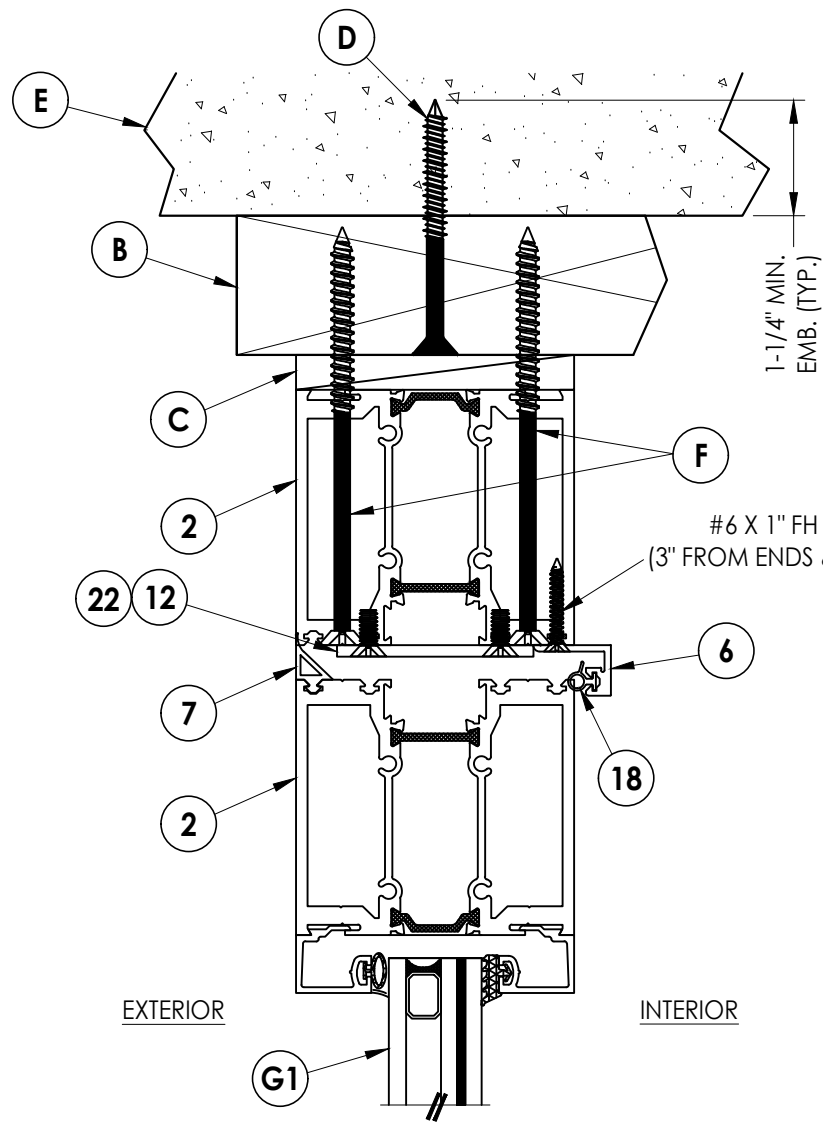

**1 VERTICAL CROSS SECTION**  
4 Shown w/ 2X Buck

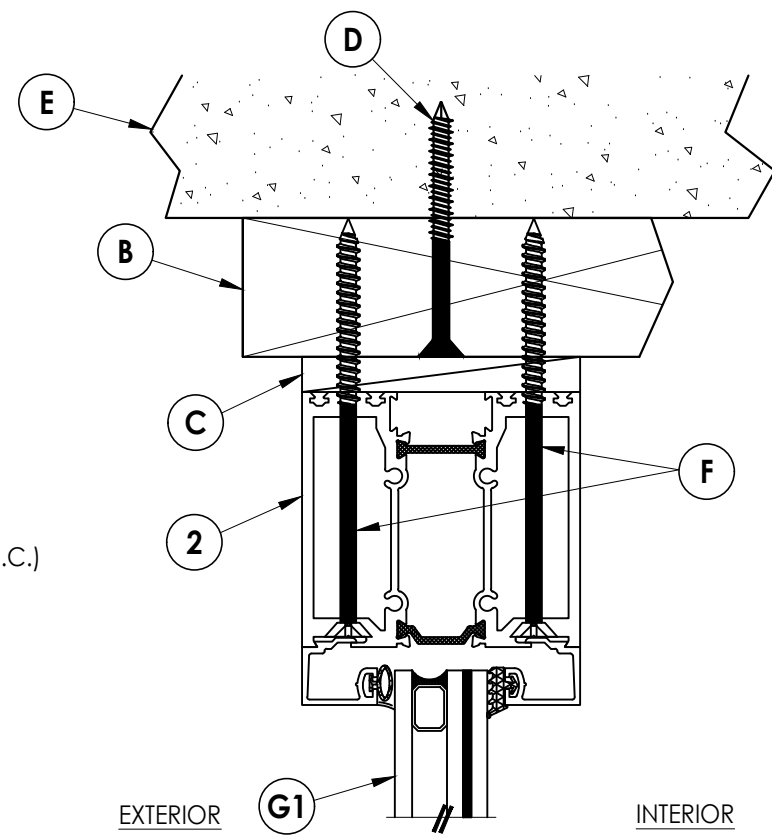

**2 VERTICAL CROSS SECTION**  
4 Shown w/ 2X Buck

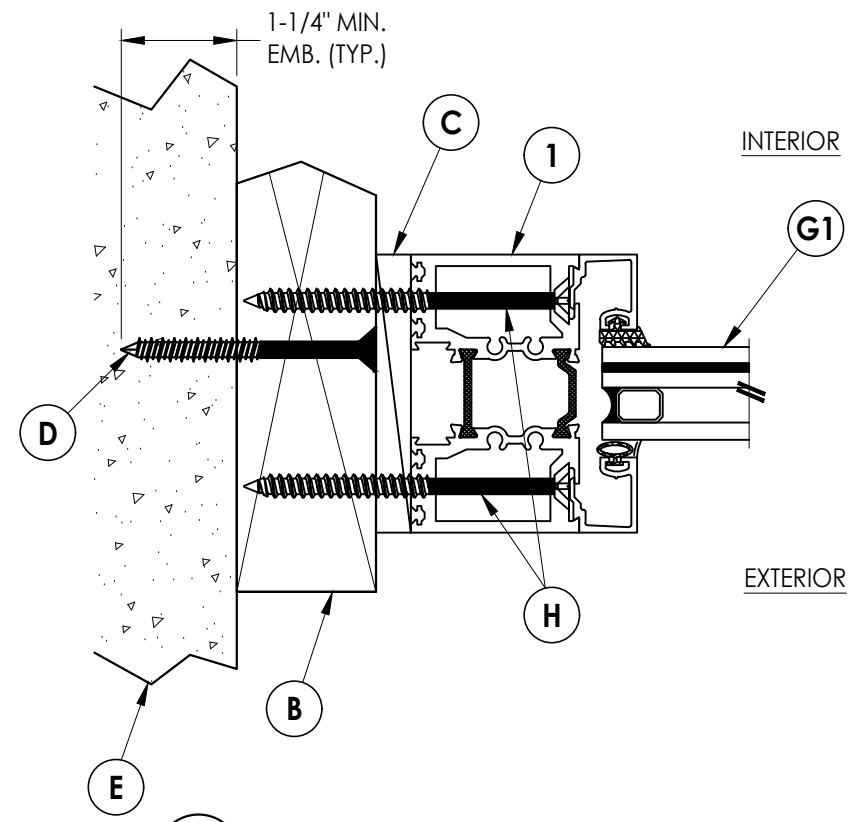

**3 HORIZONTAL CROSS SECTION**  
4 Shown w/ 2X Buck

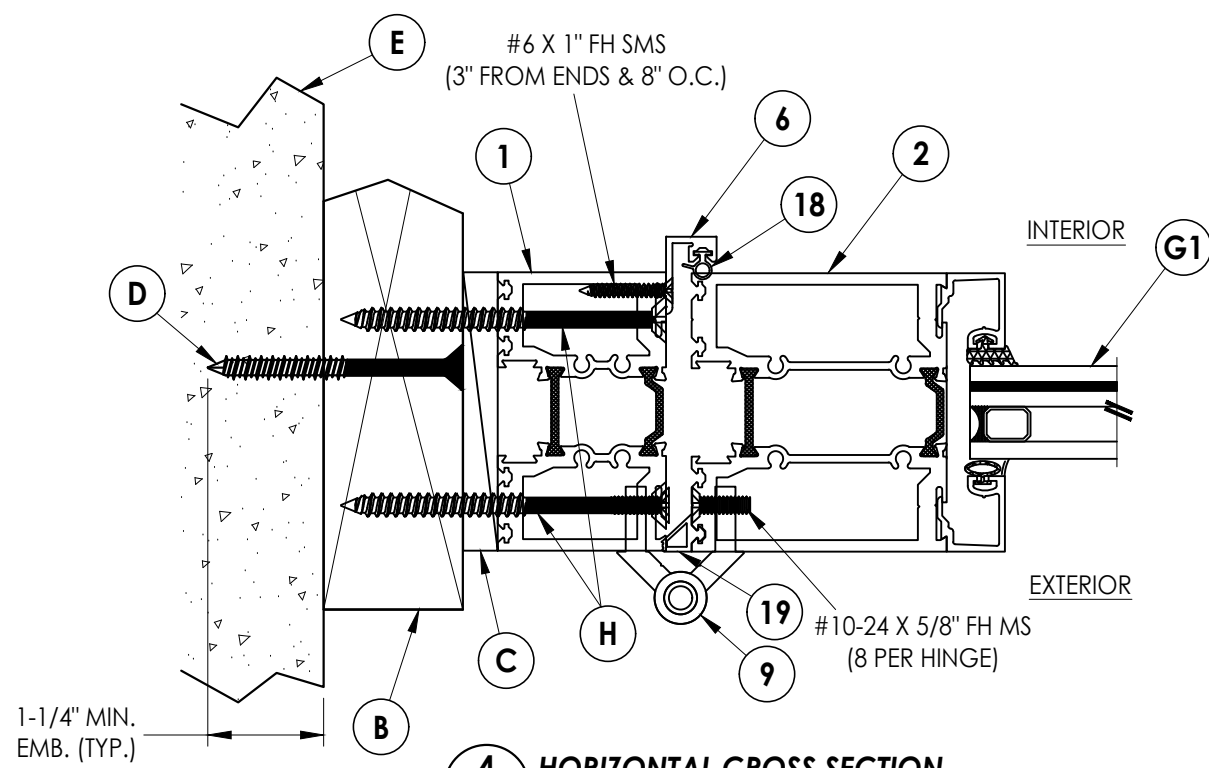

**4 HORIZONTAL CROSS SECTION**  
4 Shown w/ 2X Buck

Documents Prepared By:  
Lyndon F. Schmidt  
P.E. No. 43409

**RW** BUILDING CONSULTANTS, INC.  
P.O. Box 230, Valrico, FL 33595  
Phone No.: 813.659.9197  
FBPE Registry No. 9813

PRODUCT: THERMA-TRU  
PART OR ASSEMBLY: HORIZONTAL & VERTICAL CROSS SECTIONS (2X BUCK)

NO.	DATE	BY	REVISIONS

DATE: 2/07/24  
SCALE: N.T.S.  
DWG. BY: LFS  
CHK. BY: RW  
DRAWING NO.: FL-46172.6  
SHEET 4 OF 11

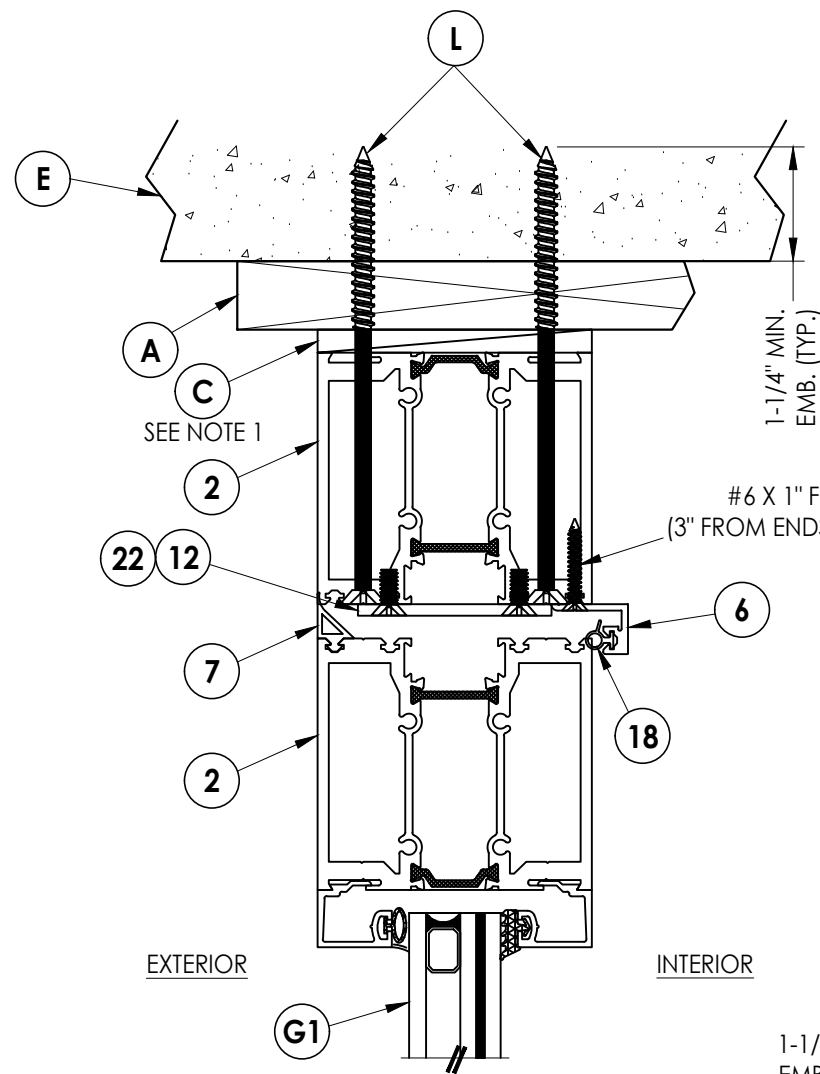

**1** VERTICAL CROSS SECTION  
5 Shown w/ 1X Buck

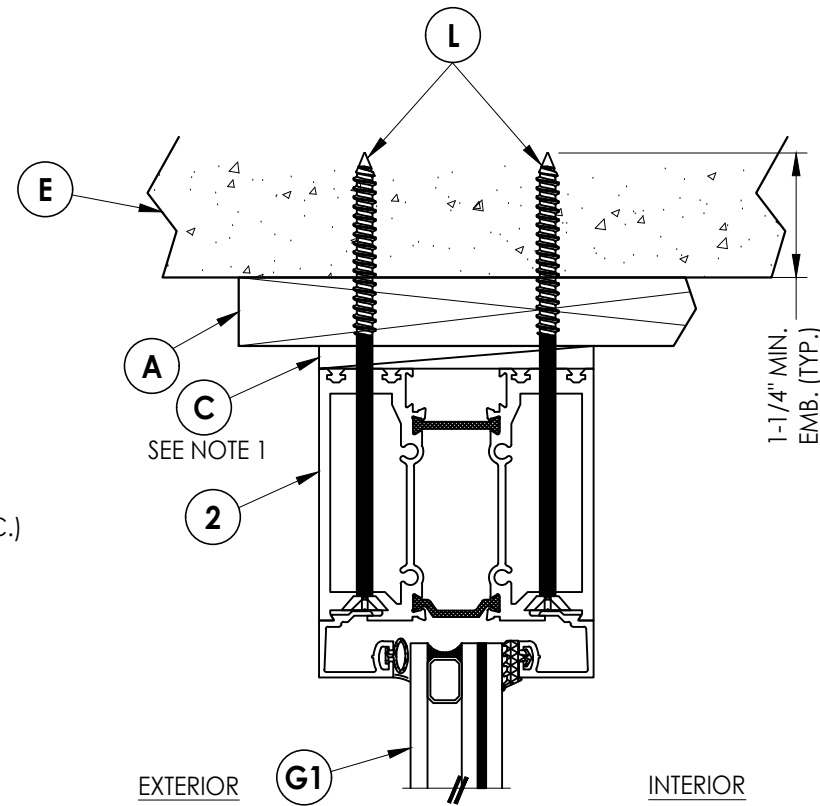

**2** VERTICAL CROSS SECTION  
5 Shown w/ 1X Buck

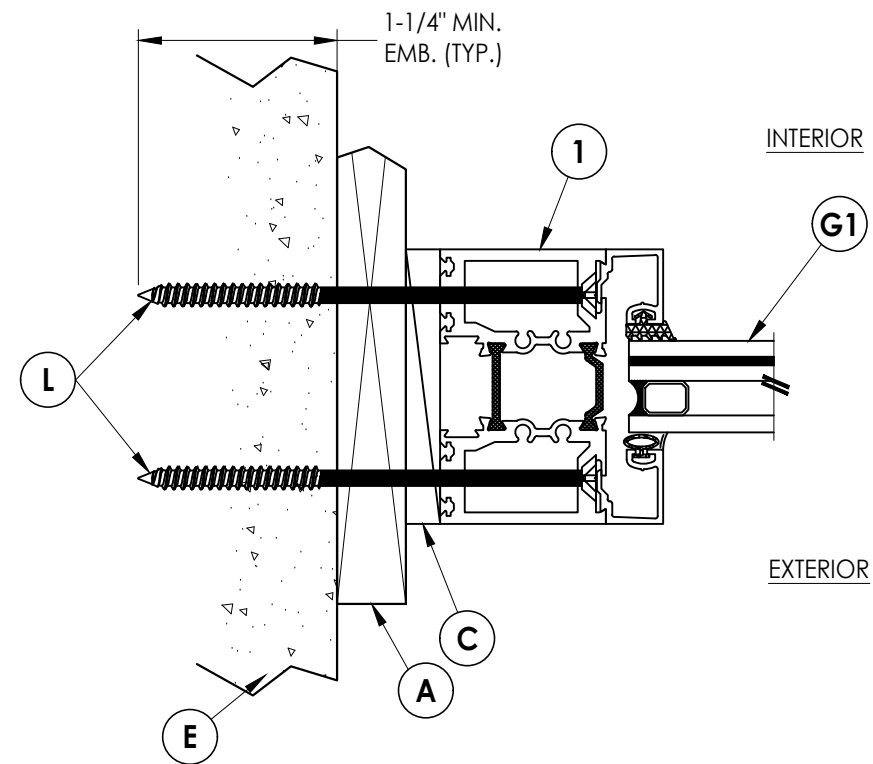

**3** HORIZONTAL CROSS SECTION  
5 Shown w/ 1X Buck

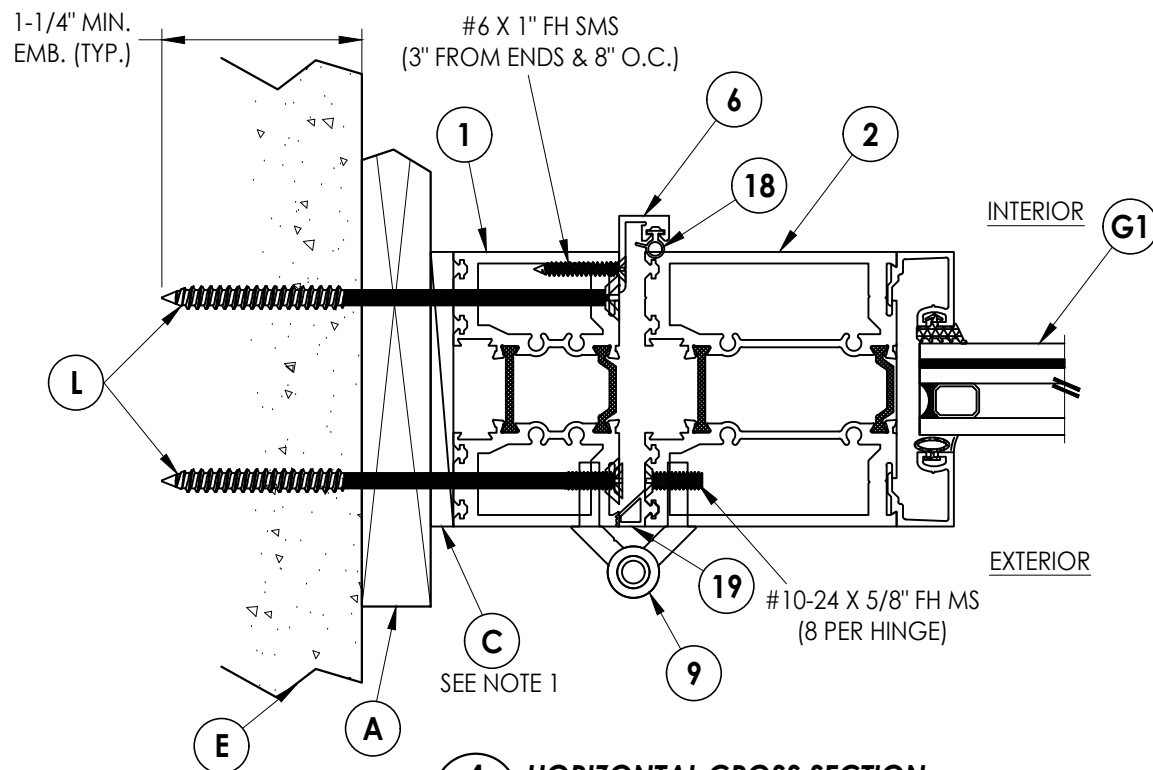

**4** HORIZONTAL CROSS SECTION  
5 Shown w/ 1X Buck

NOTE:  
1. MAXIMUM 1/4" SHIM @ HEAD & JAMBS w/ 1X BUCK AS SHOWN.

Documents Prepared By:  
Lyndon F. Schmidt  
P.E. No. 43409

*RW* BUILDING CONSULTANTS, INC.  
P.O. Box 230, Vairico, FL 33595  
Phone No.: 813.659.9197  
FBPE Registry No. 9813

PRODUCT: THERMA-TRU

PART OR ASSEMBLY:  
HORIZONTAL & VERTICAL  
CROSS SECTIONS (1X BUCK)

NO.	DATE	BY	REVISIONS

DATE: 2/07/24  
SCALE: N.T.S.  
DWG. BY: LFS  
CHK. BY: RW  
DRAWING NO.: FL-46172.6  
SHEET 5 OF 11

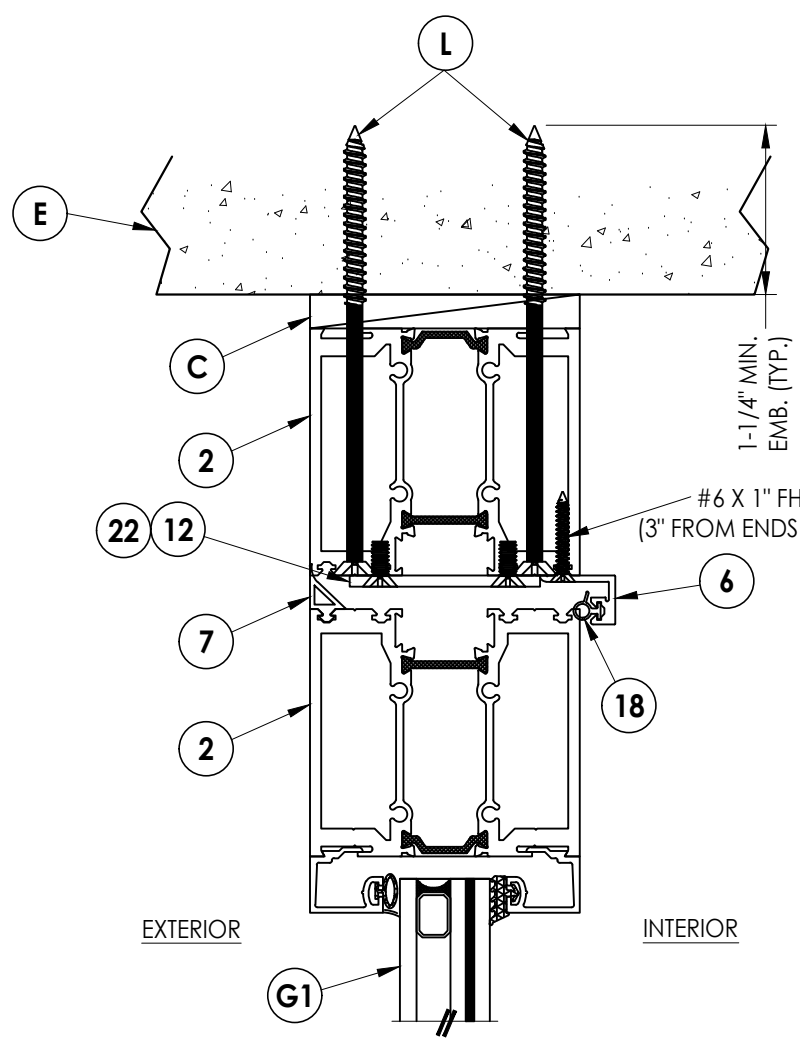

**1 VERTICAL CROSS SECTION**  
6 Shown Direct to Masonry

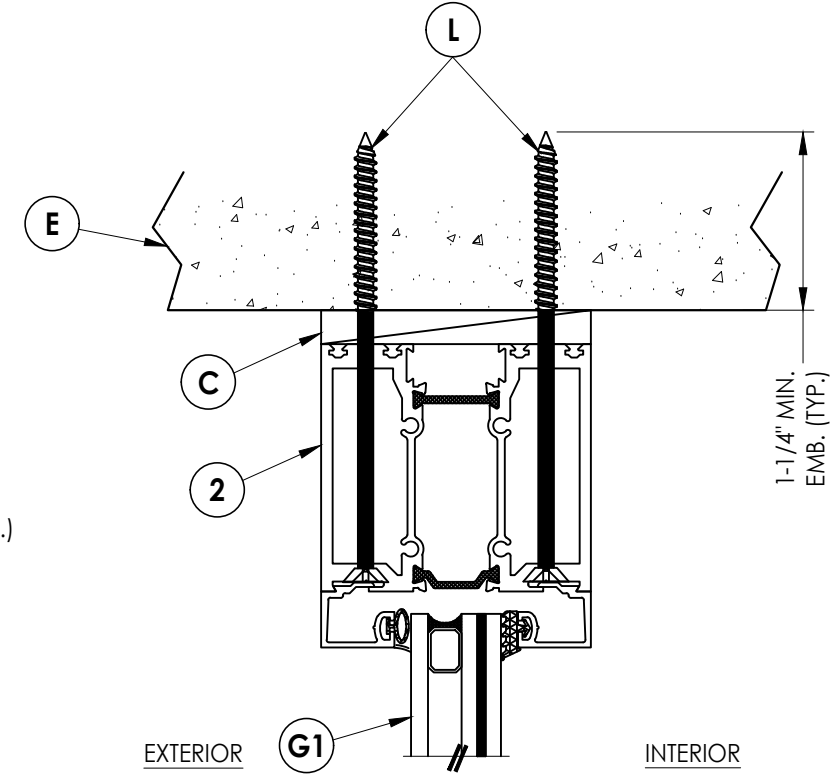

**2 VERTICAL CROSS SECTION**  
6 Shown Direct to Masonry

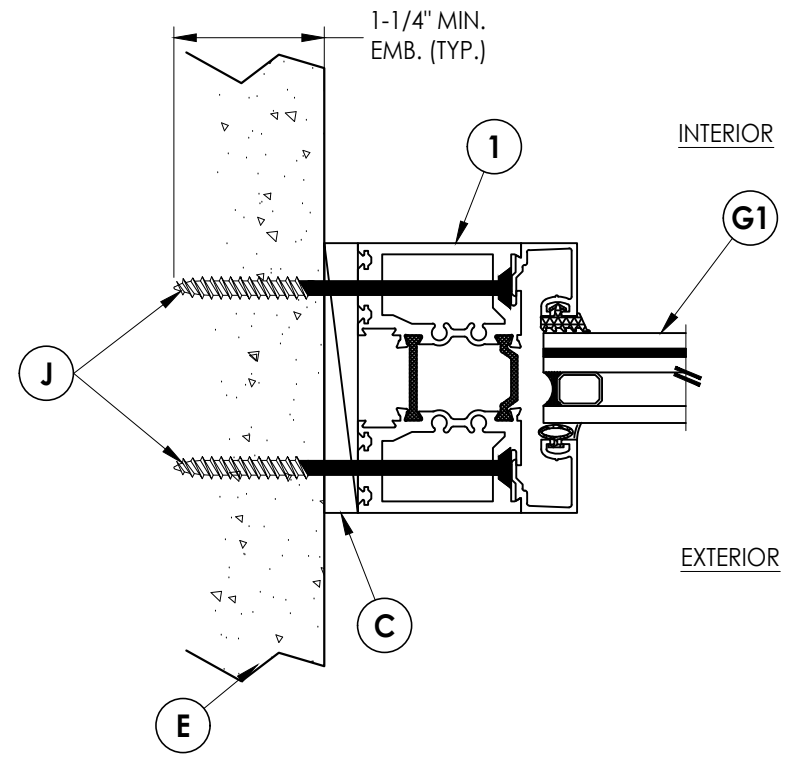

**3 HORIZONTAL CROSS SECTION**  
6 Shown Direct to Masonry

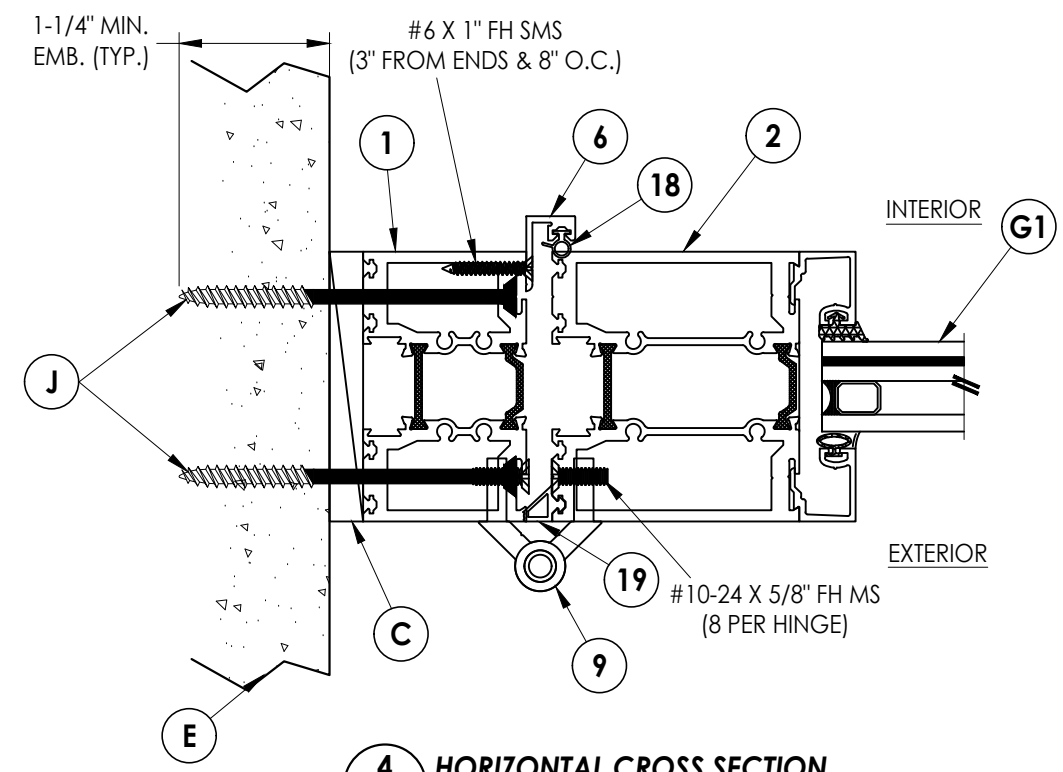

**4 HORIZONTAL CROSS SECTION**  
6 Shown Direct to Masonry

Documents Prepared By:  
Lyndon F. Schmidt  
P.E. No. 43409

**RW** BUILDING CONSULTANTS, INC.  
P.O. Box 230, Valrico, FL 33595  
Phone No.: 813.659.9197  
FBPE Registry No. 9813

PRODUCT: THERMA-TRU

PART OR ASSEMBLY:  
HORIZONTAL & VERTICAL CROSS  
SECTIONS (DIRECT TO MASONRY)

NO.	DATE	BY	REVISIONS

DATE: 2/07/24  
SCALE: N.T.S.  
DWG. BY: LFS  
CHK. BY: RW  
DRAWING NO.: FL-46172.6  
SHEET 6 OF 11

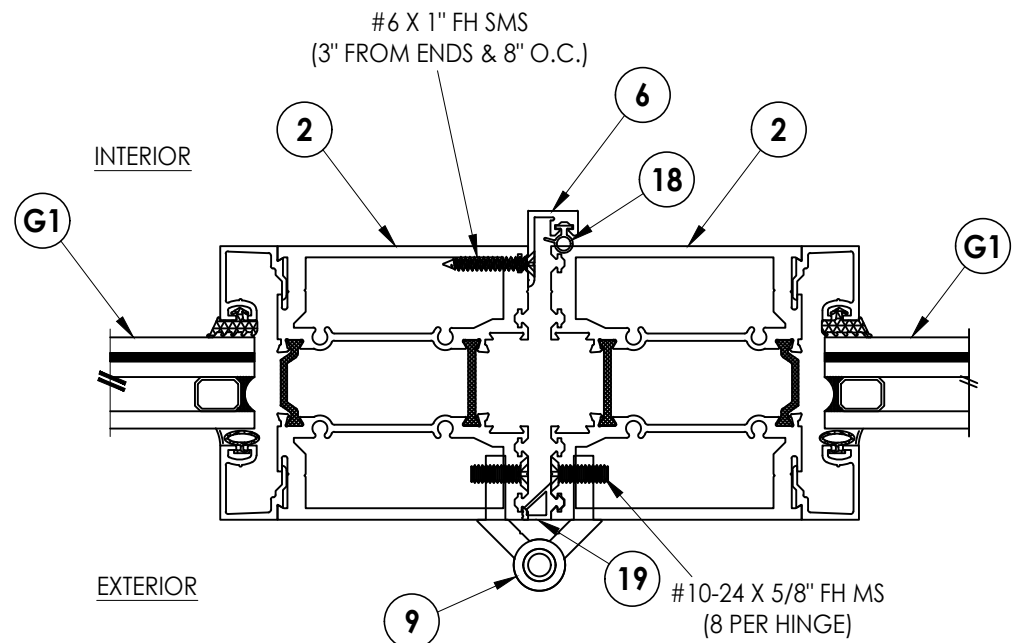

**1**  
**7** HORIZONTAL CROSS SECTION

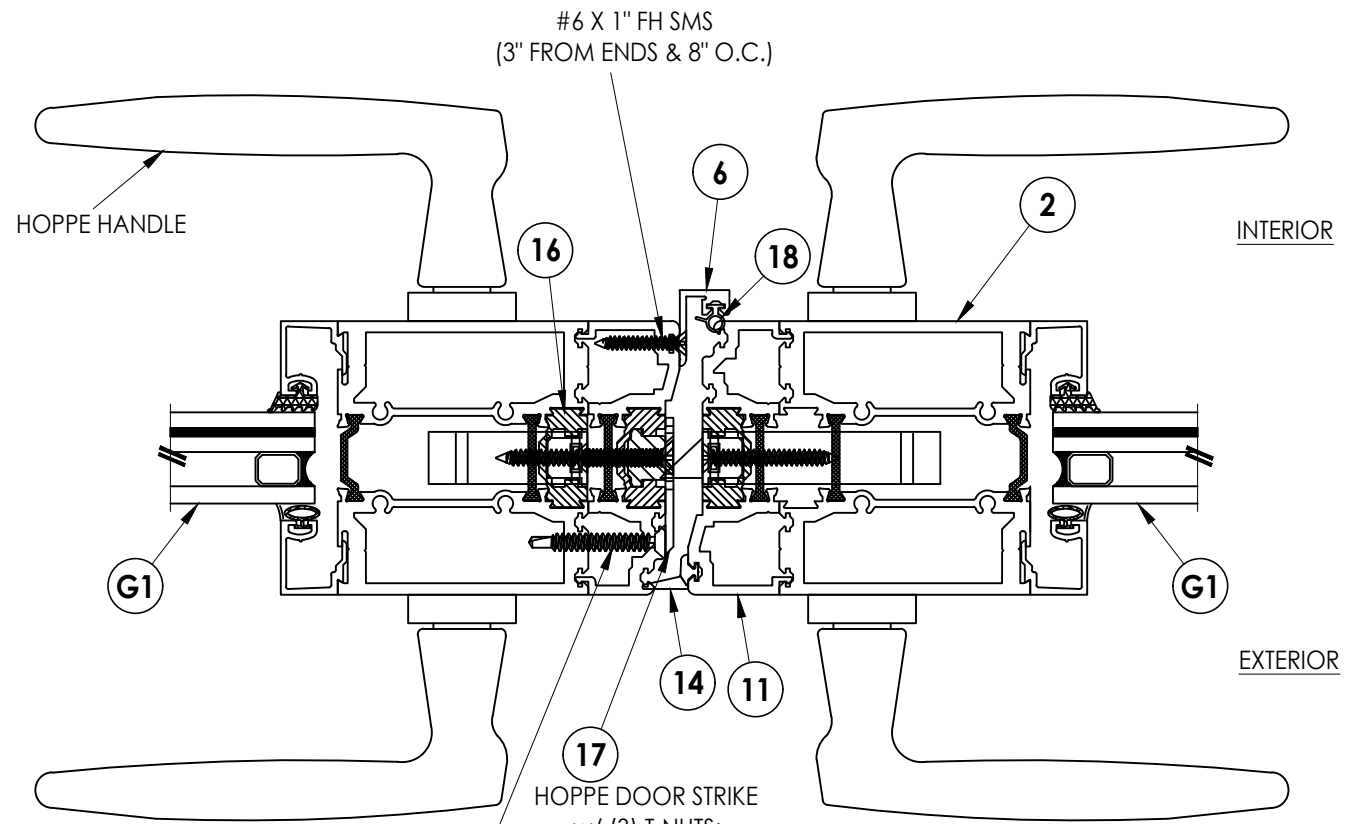

(5) #10 X 1-1/2" TEK SCREWS 6" FROM ENDS, @ 3" ABOVE & BELOW STRIKE PLUS @ CENTERLINE  
 (2) 10-32 X 5/8" MS  
 (1) 10-32 X 1" MS  
 HOPPE DOOR STRIKE w/ (3) T-NUTS:

**2**  
**7** HORIZONTAL CROSS SECTION

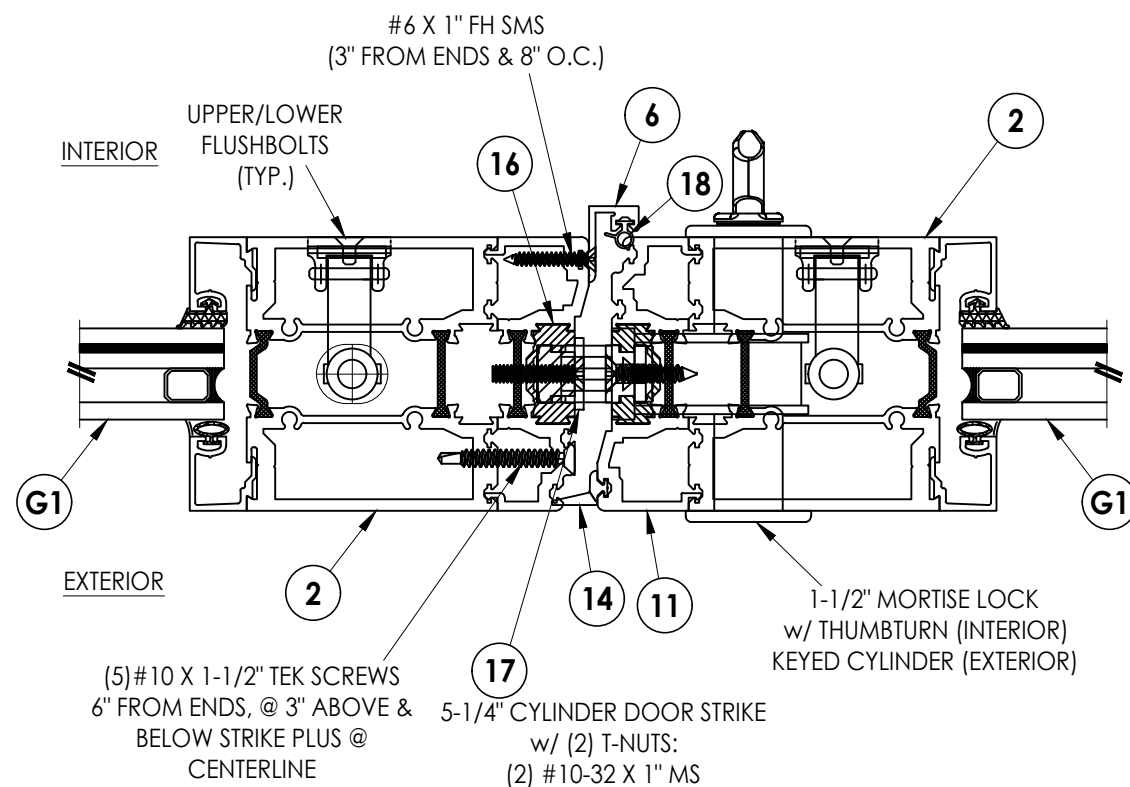

(5) #10 X 1-1/2" TEK SCREWS 6" FROM ENDS, @ 3" ABOVE & BELOW STRIKE PLUS @ CENTERLINE  
 (2) #10-32 X 1" MS  
 5-1/4" CYLINDER DOOR STRIKE w/ (2) T-NUTS:

**3**  
**7** HORIZONTAL CROSS SECTION

Documents Prepared By:  
 Lyndon F. Schmidt  
 P.E. No. 43409

*RW* BUILDING CONSULTANTS, INC.  
 P.O. Box 230, Vairico, FL 33595  
 Phone No.: 813.659.9197  
 FBPE Registry No. 9813

PRODUCT: THERMA-TRU

PART OR ASSEMBLY: HORIZONTAL CROSS SECTIONS

NO.	DATE	BY	REVISIONS

DATE: 2/07/24  
 SCALE: N.T.S.  
 DWG. BY: LFS  
 CHK. BY: RW  
 DRAWING NO.: FL-46172.6  
 SHEET 7 OF 11

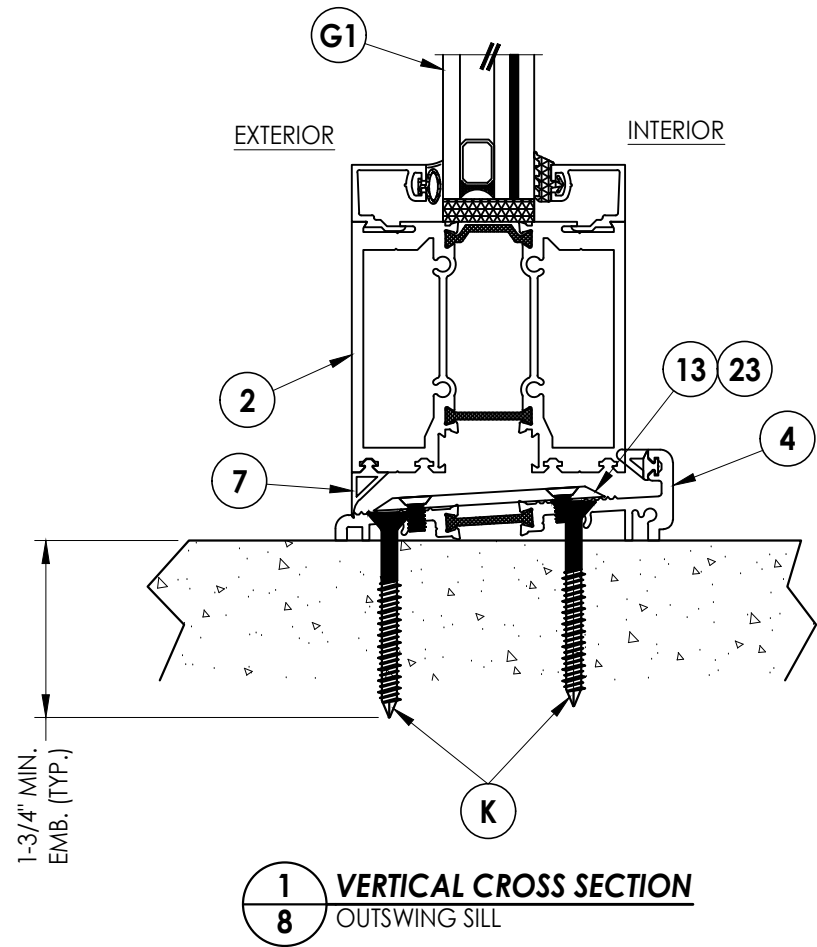

**1** VERTICAL CROSS SECTION  
**8** OUTSWING SILL

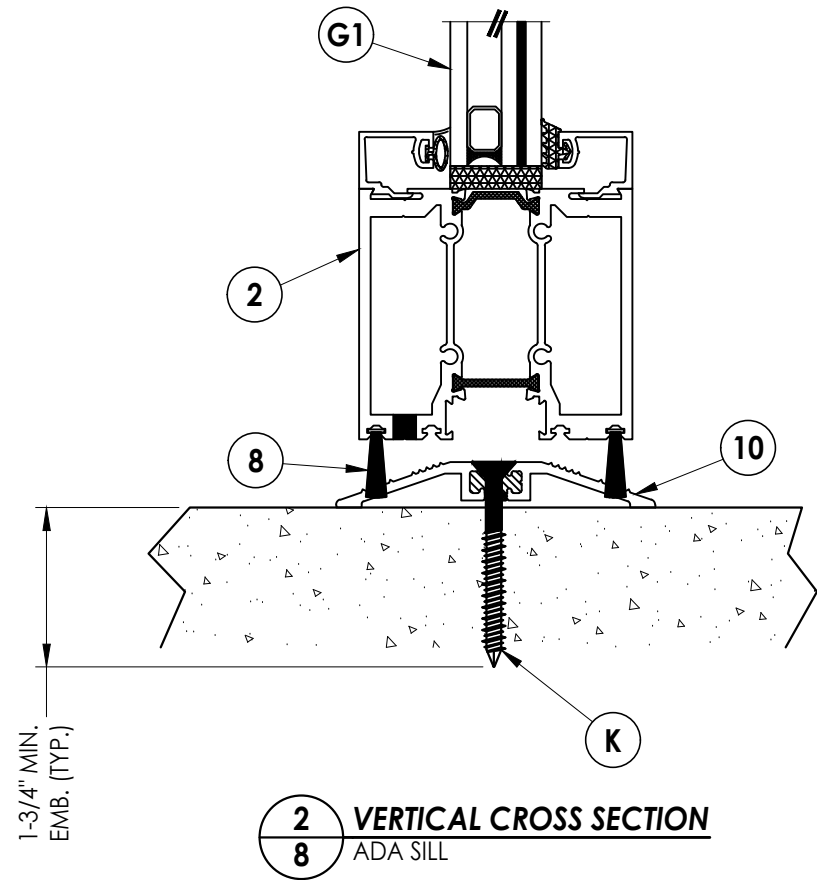

**2** VERTICAL CROSS SECTION  
**8** ADA SILL

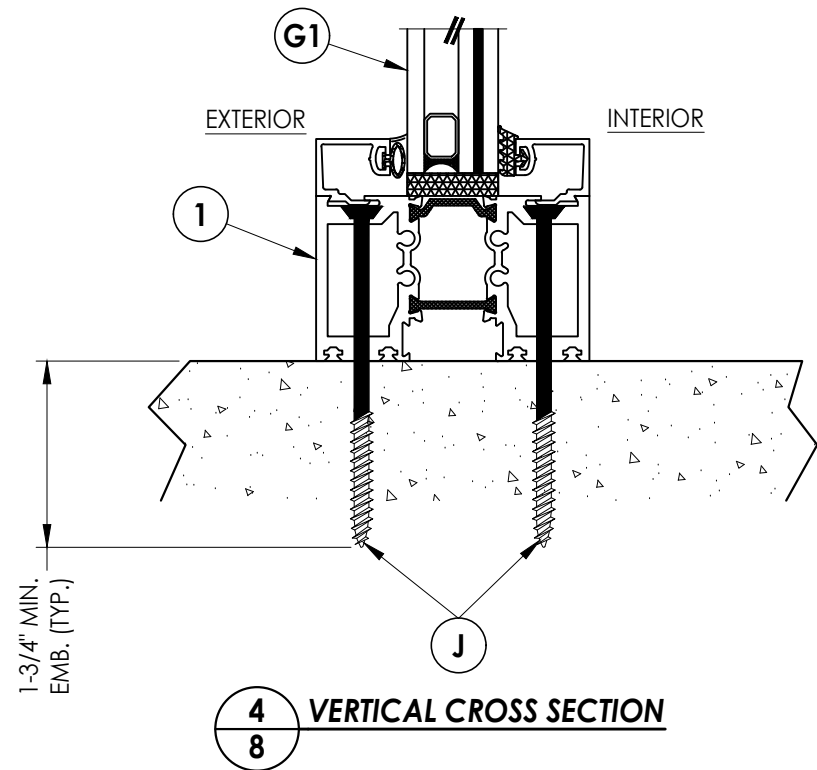

**4** VERTICAL CROSS SECTION  
**8**

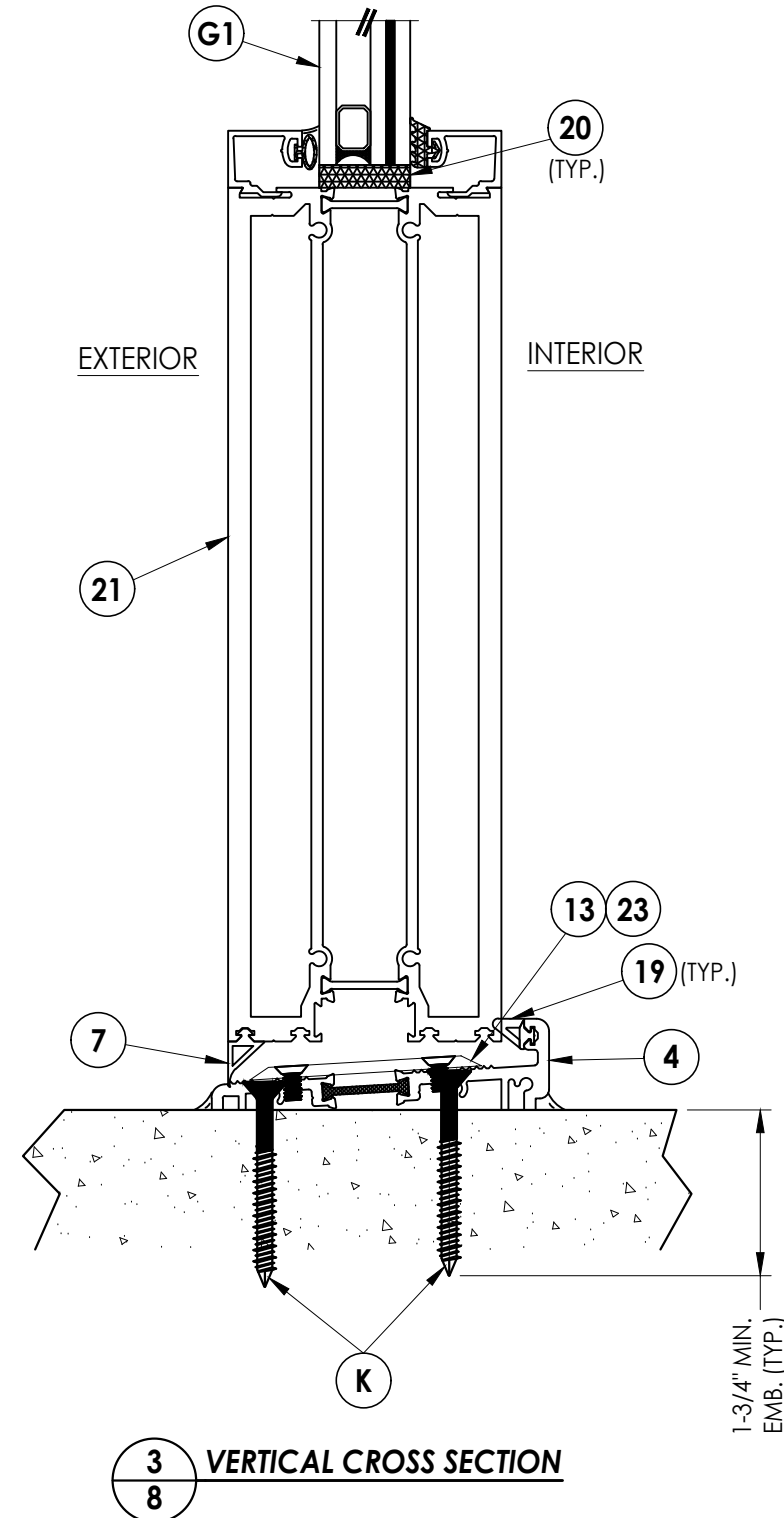

**3** VERTICAL CROSS SECTION  
**8**

Documents Prepared By:  
Lyndon F. Schmidt  
P.E. No. 43409

*RW* BUILDING CONSULTANTS, INC.  
P.O. Box 230, Valrico, FL 33595  
Phone No.: 813.659.9197  
FBPE Registry No. 9813

PRODUCT: THERMA-TRU

PART OR ASSEMBLY:  
VERTICAL CROSS SECTIONS

NO.	DATE	BY

DATE: 2/07/24  
SCALE: N.T.S.  
DWG. BY: JK  
CHK. BY: RW  
DRAWING NO.: FL-46172.6  
SHEET 8 OF 11



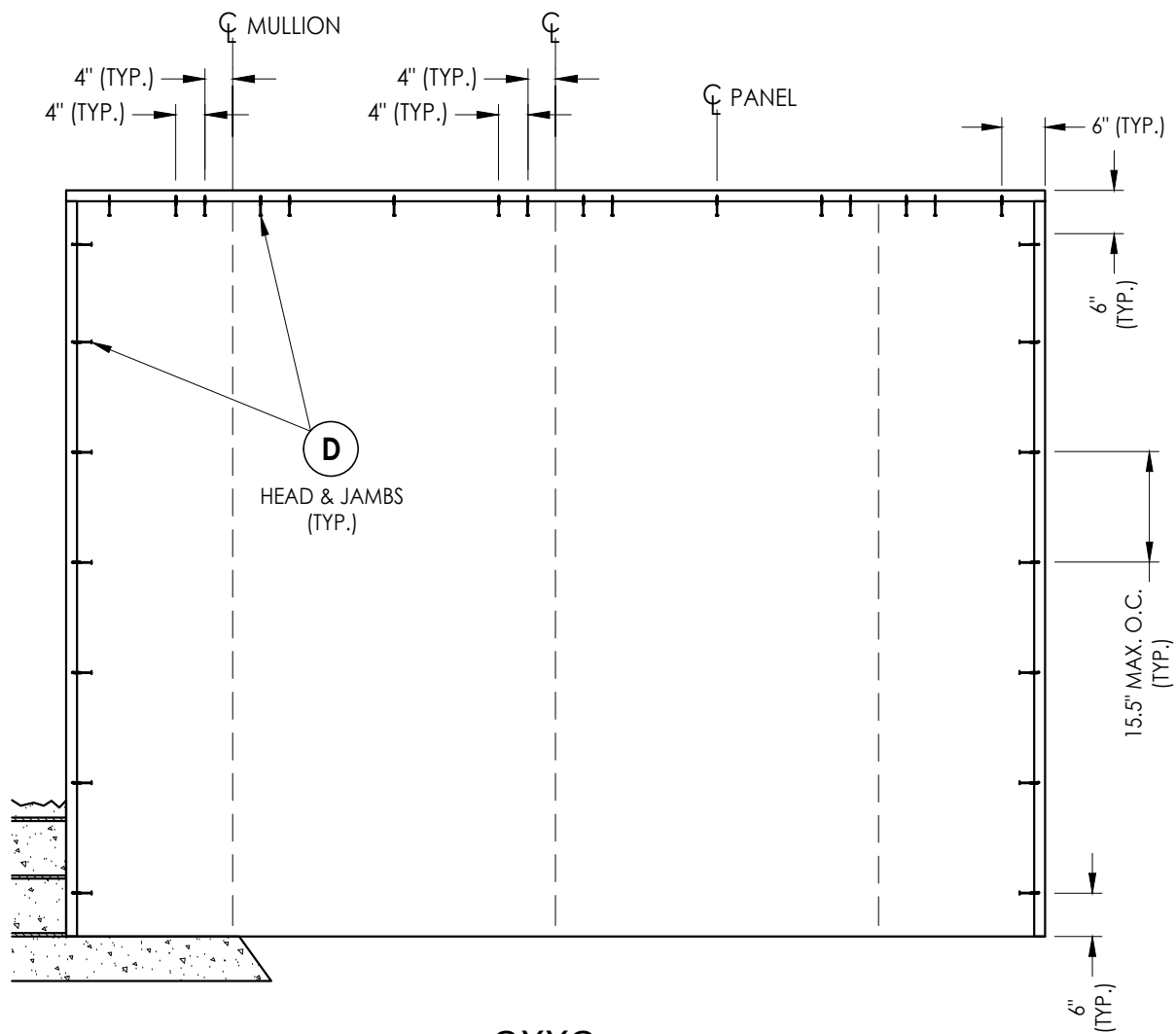
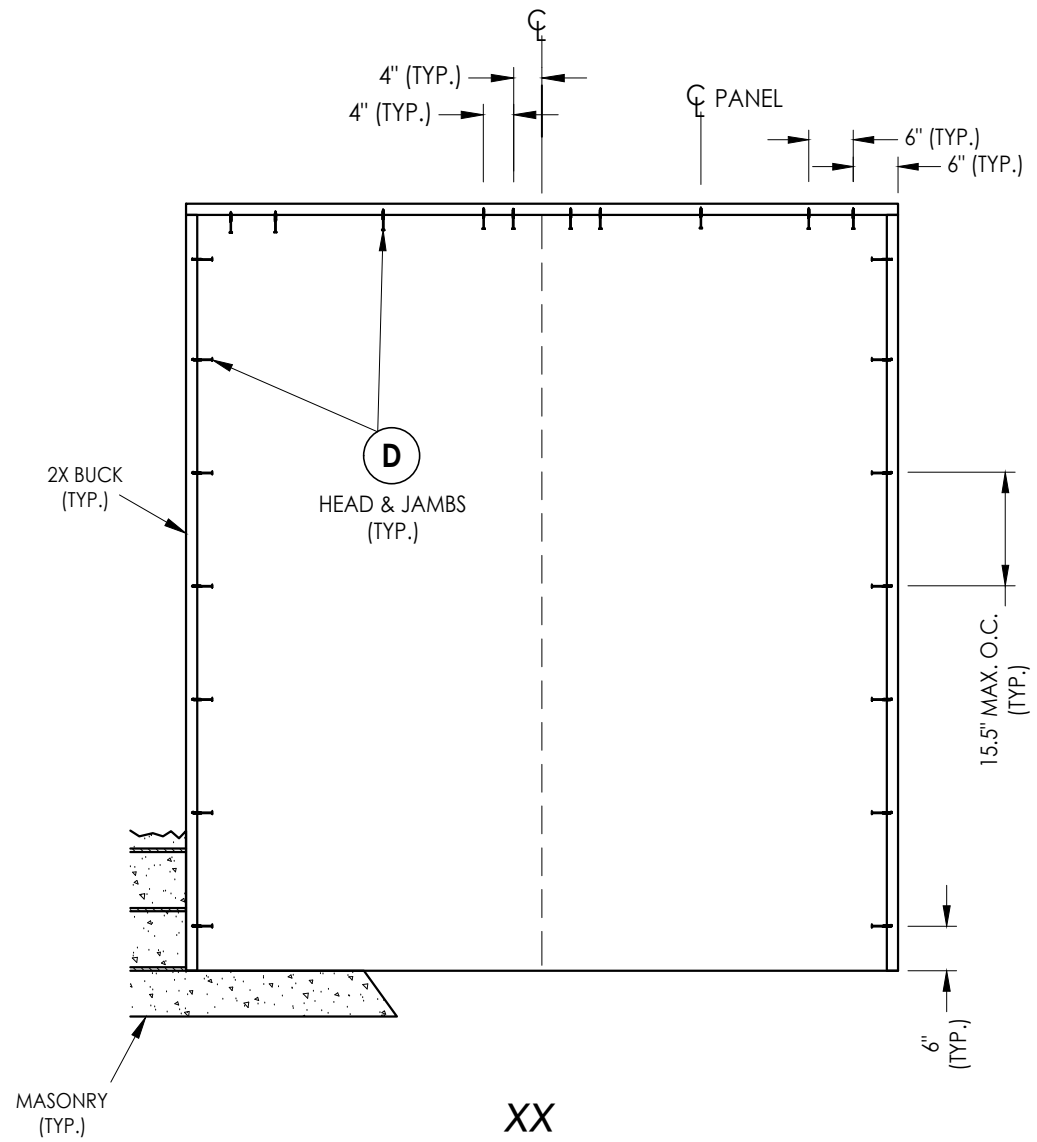

## 2X BUCK ANCHORING

**CONCRETE ANCHOR NOTES:**

1. Concrete anchor locations at the corners may be adjusted to maintain the min. edge distance to mortar joints.
2. Concrete anchor locations noted as "MAX. ON CENTER" must be adjusted to maintain the min. edge distance to mortar joints, additional concrete anchors may be required to ensure the "MAX. ON CENTER" dimension are not exceeded.
3. Concrete anchor table:

ANCHOR TYPE	ANCHOR SIZE	MIN. EMBEDMENT	MIN. CLEARANCE TO MASONRY EDGE	MIN. CLEARANCE TO ADJACENT ANCHOR
ITW TAPCON®	1/4"	1-1/4" 1-3/4" (SILL)	2"	4"
DeWALT ULTRACON®	1/4"	1-1/4" 1-3/4" (SILL)	1"	4"

**WOOD SCREW INSTALLATION NOTES:**

1. Maintain a minimum 5/8" edge distance, 1" end distance, & 1" o.c. spacing of wood screws to prevent the splitting of wood.

Documents Prepared By:  
Lyndon F. Schmidt  
P.E. No. 43409

**RW** BUILDING CONSULTANTS, INC.  
P.O. Box 230, Vairico, FL 33595  
Phone No.: 813.659.9197  
FBPE Registry No. 9813

PRODUCT: THERMA TRU

PART OR ASSEMBLY:  
BUCK ANCHORING

NO.	DATE	BY

DATE: 2/07/24

SCALE: N.T.S.

DWG. BY: JK

CHK. BY: RW

DRAWING NO.:  
FL-46172.6

SHEET 9 OF 11

NOTE: ALL ANCHORS SHOWN ARE STAGGERED EXCEPT FOR THE ADA SILL ANCHORS (SEE CROSS-SECTIONS)

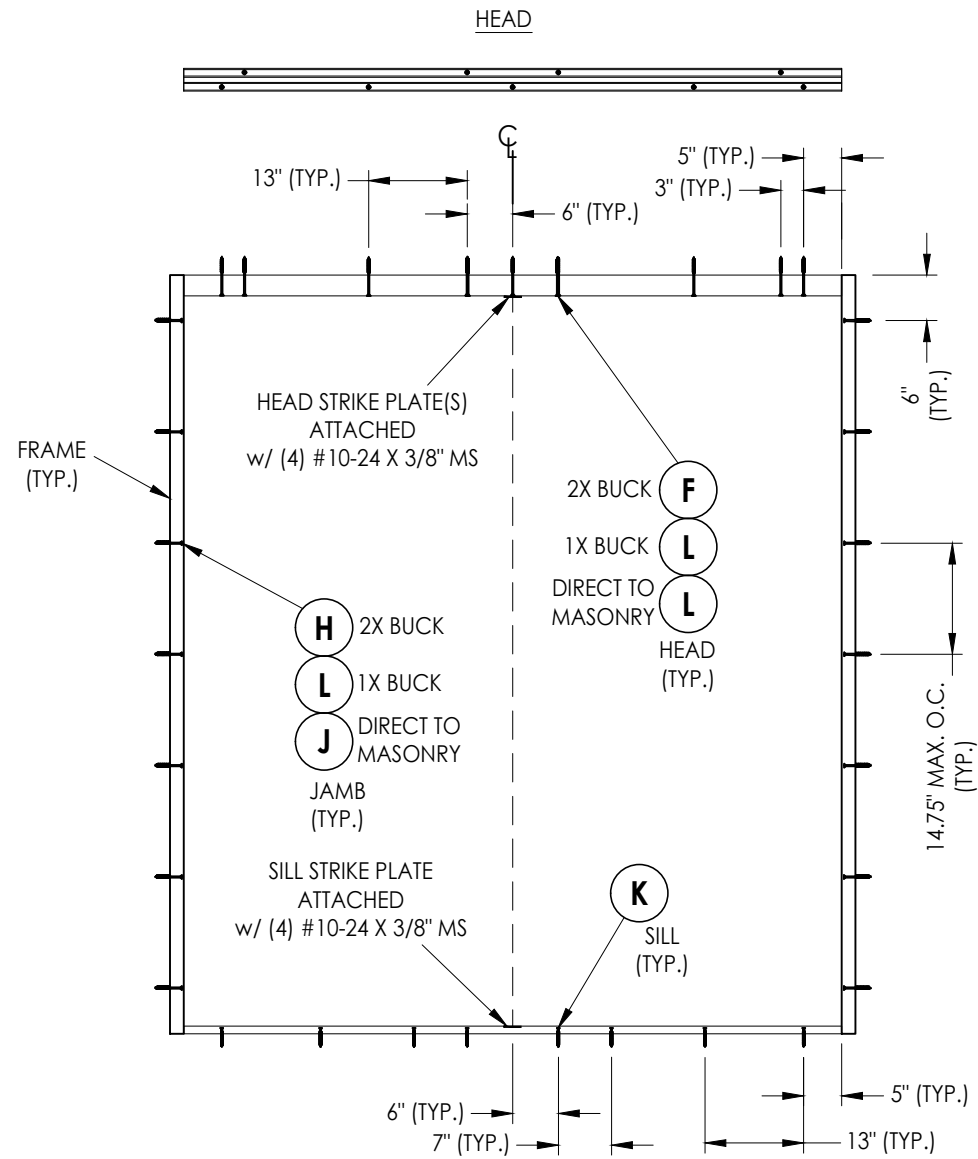

XX



OUTSWING SILL



ADA SILL

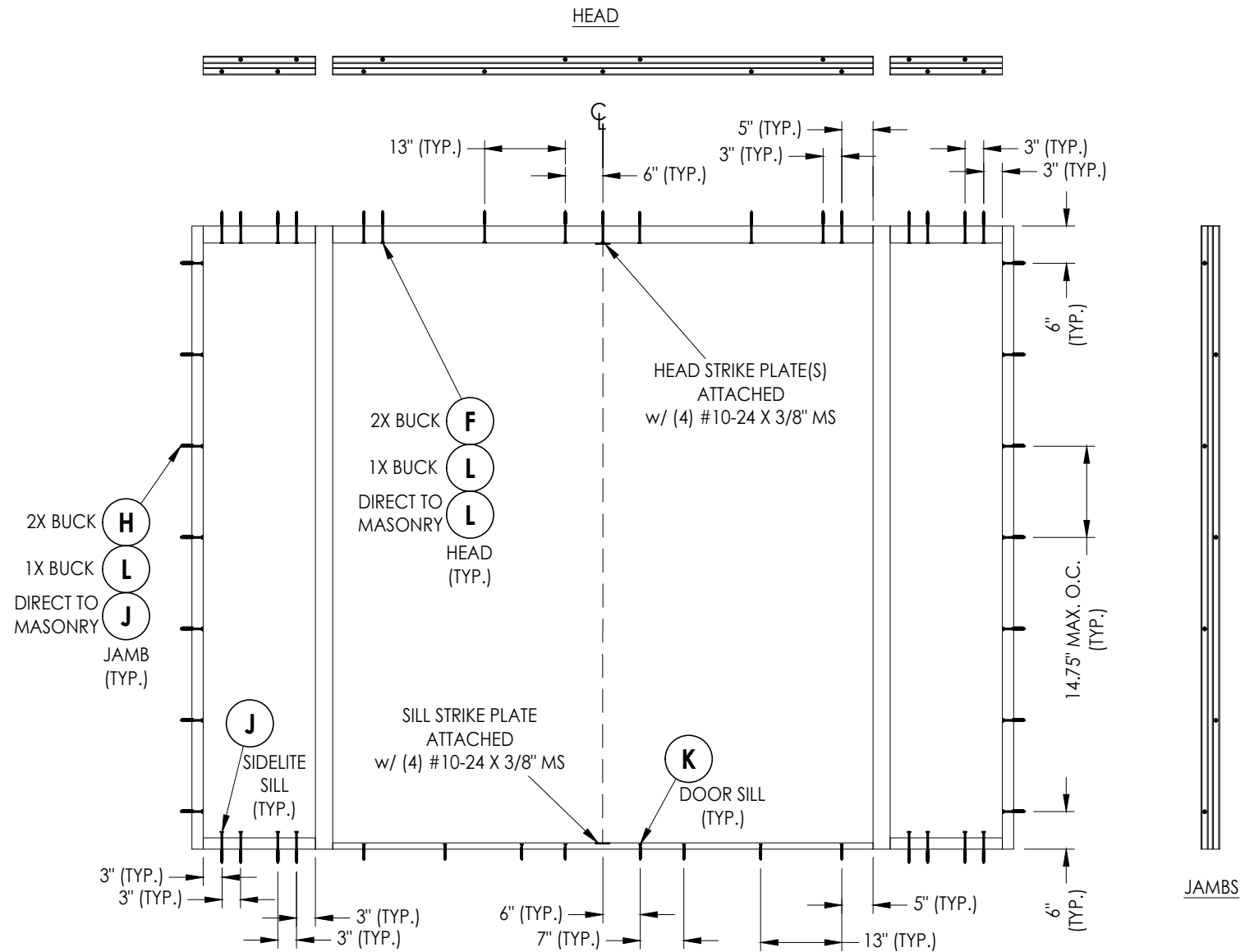

OXXO



OUTSWING SILL



ADA SILL



JAMBS

# FRAME ANCHORING

Documents Prepared By:  
Lyndon F. Schmidt  
P.E. No. 43409

**R.W.** BUILDING CONSULTANTS, INC.  
P.O. Box 230, Valrico, FL 33595  
Phone No.: 813.659.9197  
FBPE Registry No. 9813

PRODUCT: THERMA TRU  
PART OR ASSEMBLY: FRAME ANCHORING

NO.	DATE	BY

DATE: 2/07/24  
SCALE: N.T.S.  
DWG. BY: JK  
CHK. BY: RW  
DRAWING NO.: FL-46172.6  
SHEET 10 OF 11

**BILL OF MATERIALS**

ITEM	DESCRIPTION	MATERIAL
A	1X BUCK (SG >= 0.42)	WOOD
B	2X BUCK (SG >= 0.42)	WOOD
C	3/8" MAX. SHIM SPACE	-
D	1/4" X 2-3/4" PFH DeWALT OR ITW CONCRETE SCREW	STEEL
E	MASONRY - 3,000 PSI MIN. CONCRETE CONFORMING TO ACI 301 OR HOLLOW BLOCK CONFORMING TO ASTM C90	CONCRETE
F	#14 X 4-1/2" FH SMS (1-1/4" MIN. EMBEDMENT)	S.S.
H	#14 X 3-1/2" FH SMS (1-1/4" MIN. EMBEDMENT)	S.S.
J	1/4" X 3-3/4" PFH DeWALT OR ITW CONCRETE SCREW	STEEL
K	1/4" X 2-1/4" PFH DeWALT OR ITW CONCRETE SCREW	STEEL
L	1/4" X 5" PFH DeWALT OR ITW CONCRETE SCREW	STEEL
1	LT NARROW FRAME	6063-T6 ALUM
2	LT FRAME	6063-T6 ALUM
4	OUTSWING SILL	6063-T6 ALUM
5	1/4" GLASS STOP	6063-T6 ALUM
6	SLIDE-IN DOOR STOP	6063-T5 ALUM
7	DOOR SILL GASKET	-
8	3/4" BRUSH WEATHERSTRIP	-
9	SEMI-CONCEALED HINGE	6105-T5 ALUM
10	ADA SILL	6063-T5 ALUM
11	SWING DOOR ADAPTER	6063-T6 ALUM
12	STRIKE PLATE (@ HEAD)	S.S.
13	STRIKE PLATE (@ SILL)	S.S.
14	DOOR SWEEP FOAM GASKET	-
16	16mm EUROGROOVE	-
17	HOPPE DOOR STRIKE	S.S.
18	BULB GASKET	-
19	DOOR GASKET	-
20	SETTING BLOCK	-
21	DOOR BOTTOM PANEL	6063-T5 ALUM
22	STRIKE PLATE (@ HEAD)	S.S.
23	STRIKE PLATE (@ SILL)	S.S.

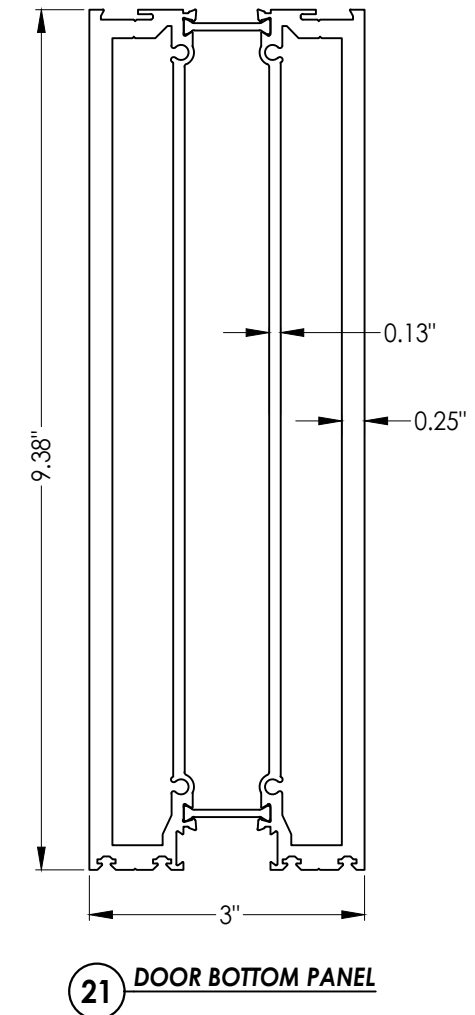
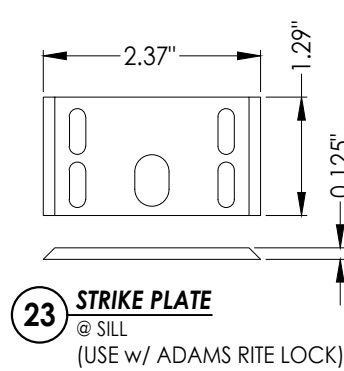
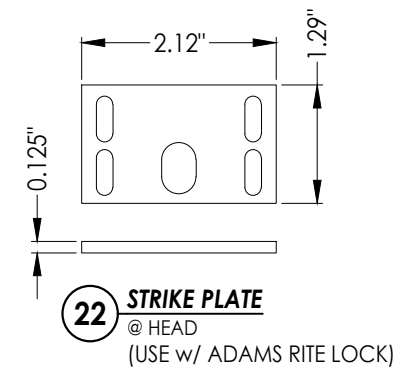
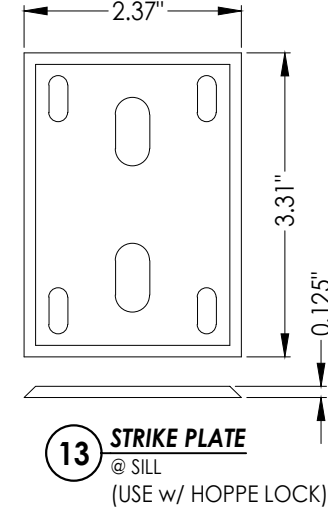
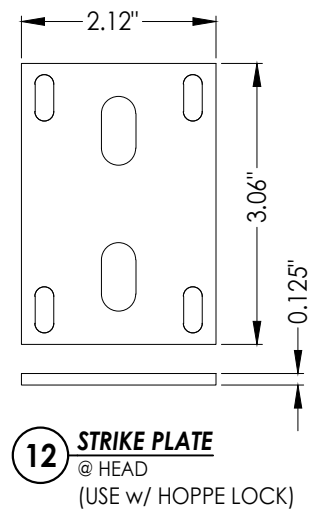
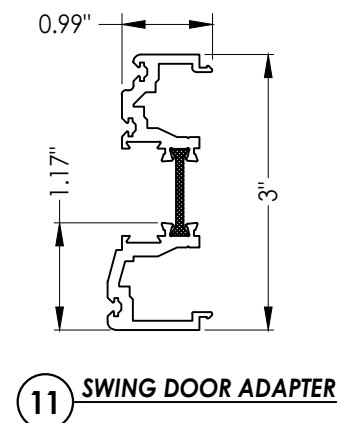
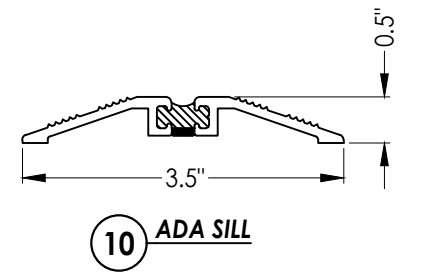
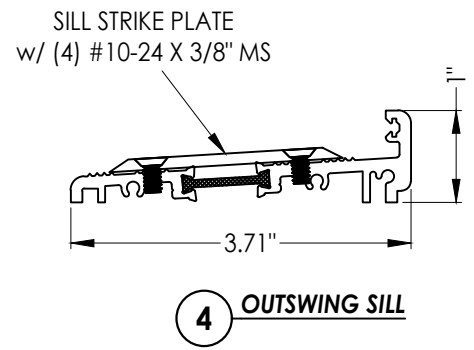
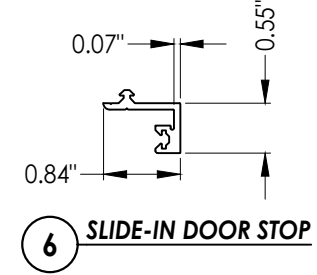
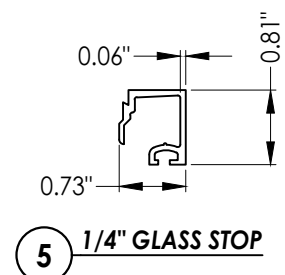
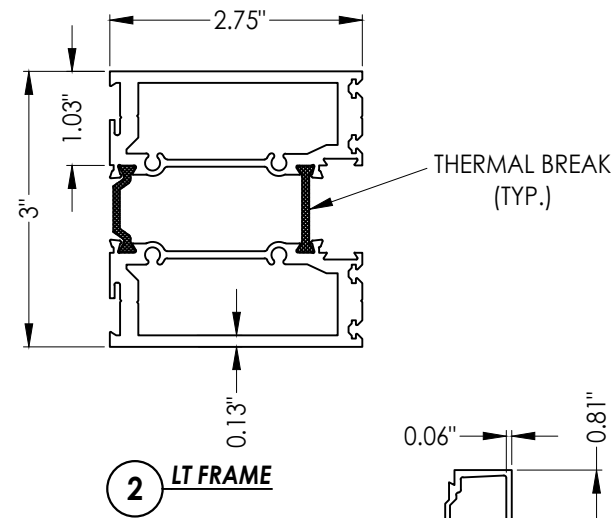
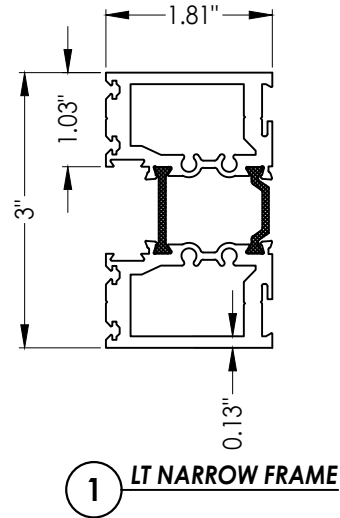

Documents Prepared By:  
Lyndon F. Schmidt  
P.E. No. 43409

**RW** BUILDING CONSULTANTS, INC.  
P.O. Box 230, Valrico, FL 33595  
Phone No.: 813.659.9197  
FBPE Registry No. 9813

PRODUCT: THERMA TRU  
PART OR ASSEMBLY: BILL OF MATERIAL & COMPONENTS

NO.	DATE	BY	REVISIONS

DATE: 2/07/24  
SCALE: N.T.S.  
DWG. BY: JK  
CHK. BY: RW  
DRAWING NO.: FL-46172.6  
SHEET 11 OF 11